



GET THAT NEXT SHOT FASTER AND EASIER.



Meet **STASIS**, Brunson's **unique scanning instrument positioner**. It's not your typical industry stand.

Typical industry stands require mounting your scanner in a fixed position. You take a shot, now you need to get the next shot. You release the locks. Move the stand. Reset the locks. Make four or five adjustments to various clamps and arms to reposition your scanner.

Let's say, at its quickest, this complex process takes 90 seconds to put you in position for the next shot.

With **STASIS**, in that same time you could have already taken **three shots**, or more. **Without moving the base.**

STASIS is the only **gimbal-style instrument mount** that allows you to directly reposition your scanner point-to-point, adjusting the **roll, pitch and yaw** of your shot, within a 10 ft. horizontal range and a maximum 8 ft. height

Again: **without moving the base.**

Watch the one-minute video at Brunson.us/stasis

SPECIFICATIONS:

Max. instrument weight: 35 lbs. [15.5 kg]

Horizontal reach: 10 ft. [3,048 mm] nominal

Maximum height: 8 ft. [2,438 mm]

Minimum height: 14 in. [356 mm]

Axes of movement: 6 rotations

Base (azimuth) – 360°

Hand (roll, pitch, yaw) – 360°

Weight excluding base: 100 lbs. [45 kg]

HORIZONTAL RANGE

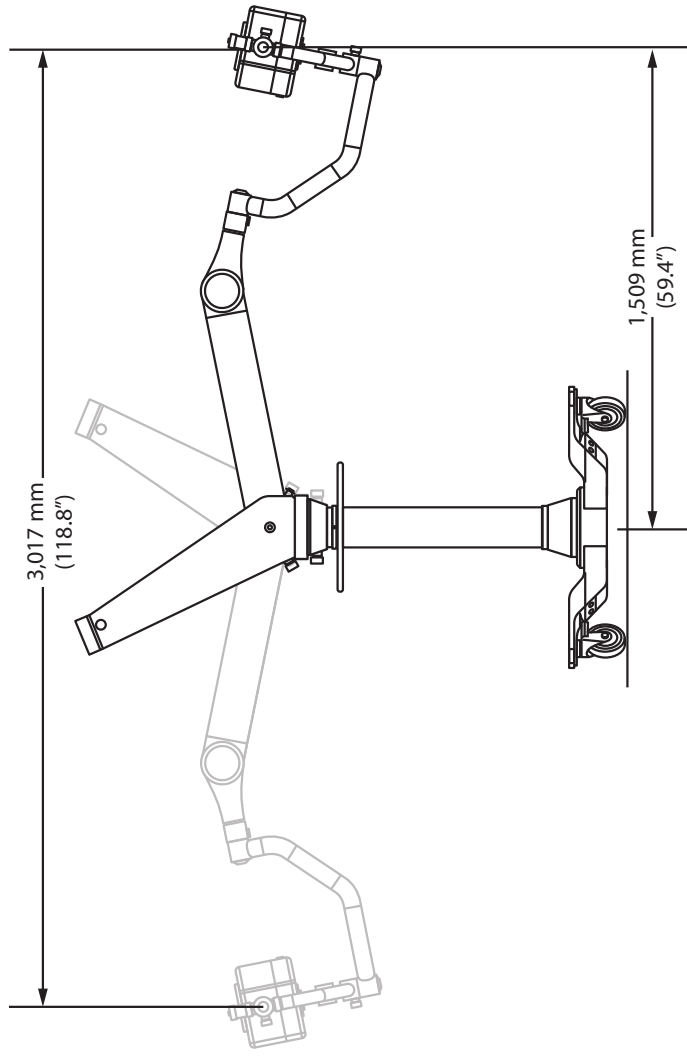

VERTICAL RANGE

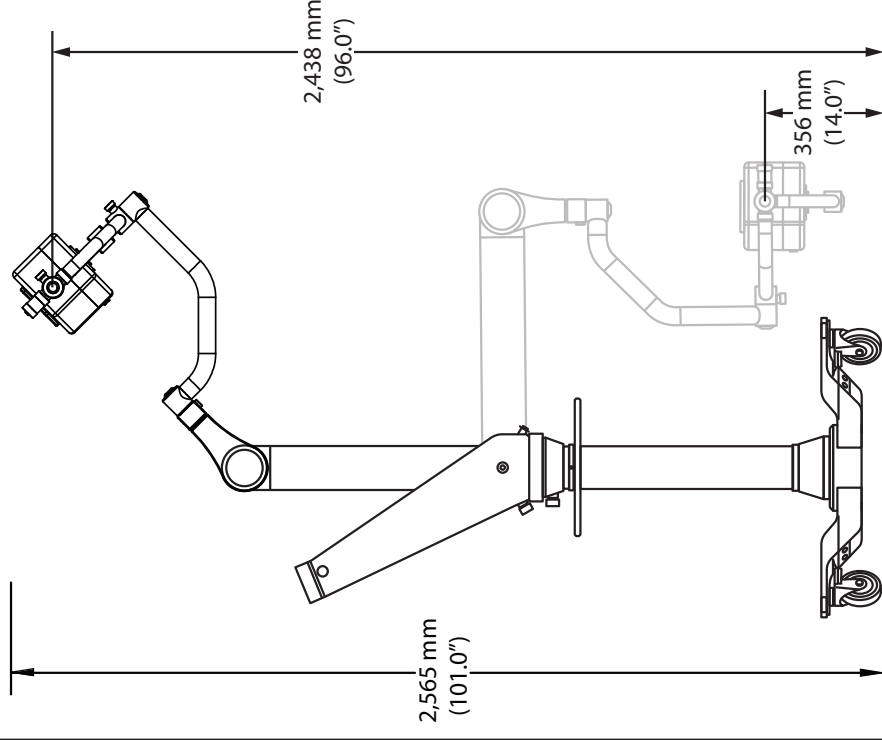

Brunson Instrument Company
8000 E. 23rd Street
Kansas City, MO 64129
www.Brunson.us

STASIS:
VERTICAL AND
HORIZONTAL RANGE