

COMMON MATERIALS

6061 ALUMINUM

7075 ALUMINUM

1144 STEEL

17-4 STAINLESS

303 STAINLESS

CUSTOM AVAILABLE

Item Number Format: 1.5THW - "MATERIAL"

Examples: 1.5THW-6061
1.5THW-303

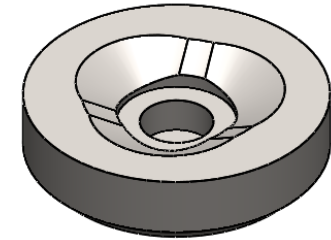

MAGNET IS INCLUDED
UNINSTALLED

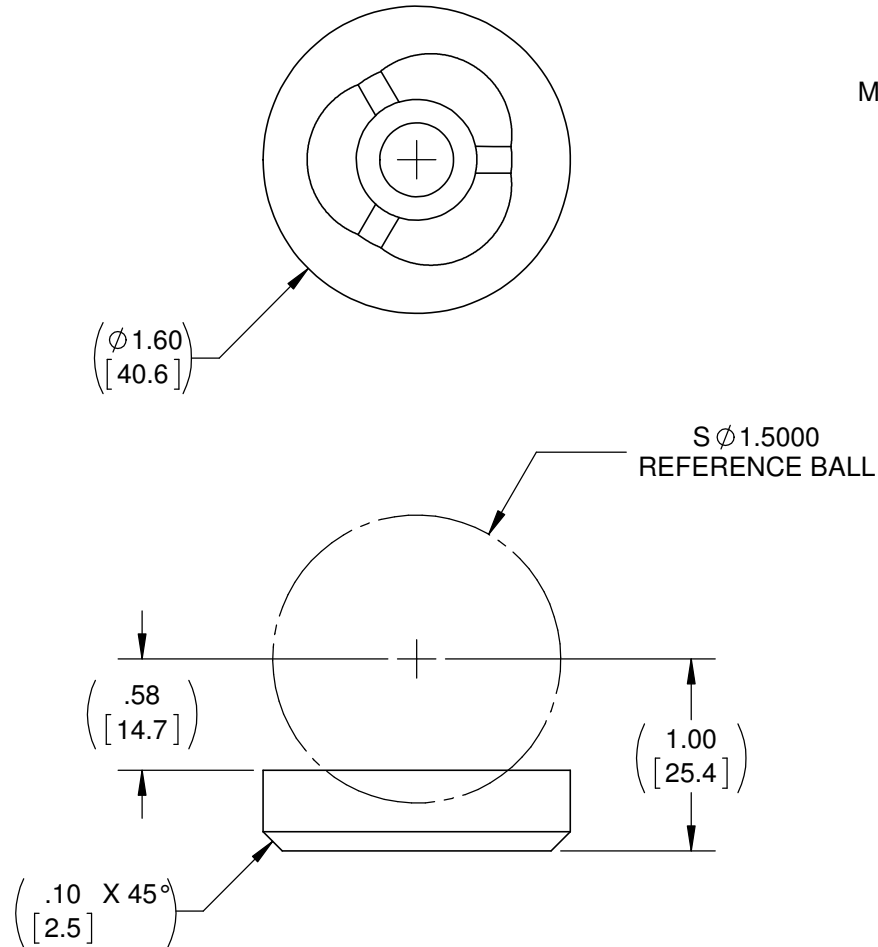

DIMENSIONS:

INCH X.XX

MM [X.XX]

REFERENCE (X.XX)

PROPRIETARY AND CONFIDENTIAL

THE INFORMATION CONTAINED IN THIS DRAWING IS THE SOLE PROPERTY OF BRUNSON INSTRUMENT COMPANY. ANY REPRODUCTION IN PART OR AS A WHOLE WITHOUT THE WRITTEN PERMISSION OF BRUNSON INSTRUMENT COMPANY IS PROHIBITED.



Brunson Instrument Company
8000 E. 23rd Street
Kansas City, MO 64129

Tel: 800-445-9405
Fax: 816-241-1945
Email: Sales@Brunson.us

TITLE: 1.5THW WELD-ON SMR ADAPTER

MATERIAL: SEE TABLE

HARDNESS: NOT HEAT TREATED

FINISH: MACHINED

WEIGHT (ESTIMATED)

0.204 LBS

SIZE

A

DATE: 1/9/2014

SCALE: 1:1